



STATIC TRANSFER SWITCH
Model *i*-STSCs

i - STS **Manufacturing** is a subsidiary of **STATIC POWER PTY. LTD.**
ABN 42 101 765 913

This manual refers to:

Model	i-STS400CsL
Rating	400 Amperes RMS
Voltage Rating	415/240 V \pm 20%
Frequency	50 Hz \pm 10%
Permissible Voltage Distortion	10% THDV
Fault rating	15 kA, 10 msec
Protection / Isolation	External
Type	Thyristor
Manufactured	June 2005
Warranty	June 2009
Maximum Ambient	40 °C
Dissipation	1250 < Watts @ 400 A RMS
IP Rating*	IP20
Maintenance Bypass	No
Bypass Interlock	External - Mechanical
Neutral Common	Yes
Fault Current Setting	2.5 times rated peak (pre-set)
Parallelable	No
Three-phase Mode	Three phase, 3 - Pole
LAN Browser	No
Modbus TCP	No
Set-up	LCD
Remote i/o	Contacts (50 V DC, 1 Ampere n/c)
Device Ratings	500 Amps, 1800 Volts ,500,000A ² S
Overload capacity	125% 10 minutes, 150% 1 minute
Minimum load current	0 Ampere
dv/dt	1000 v/usec
Synchronization Window	10 deg. (Settable 5 - 180 deg)
Break Time	< ¼ cycle
Sensing Time	< 1 msec
Environmental	
Storage	0 - 70 °C
Operating	0 - 40 °C
Humidity	5 - 90 % non condensing
Altitude	1000 m no de-rating
Audible Noise	<65 dB(A) @ 1.5 metres
Heat Output	< 1250 Watts @ 400 Amperes

* Not for outdoor use.

INDEX

1. OPERATIONAL DESCRIPTION
2. CONTROLS
3. LED INTERFACE
4. LCD INTERFACE
5. USER & IO CONTROLS
6. USER ACCESS
7. SETTINGS AND CALIBRATION
8. INSTALLATION
9. SET-UP AND COMMISSIONING
10. MAINTENANCE & BYPASS OPERATION
11. CABLING
12. INTERPRETATION OF EVENT LIST
13. FAULT DIAGNOSIS & MAINTENANCE
14. CALIBRATION
15. DRAWINGS
16. PARTS LIST
17. WARRANTY - CONTACT & SERVICE INFORMATION

1. OPERATIONAL DESCRIPTION

A Static Transfer Switch, (STS) provides your critical load or single chord (single supply), technology equipment with an alternative supply source, thus increasing and improving distribution reliability and availability.

i-STSC static transfer switches are manufactured as a three pole, three phase solid state supply change-over / transfer switch. Only the active conductors are switched. The neutral is not switched as it forms a part of the integral MEN distribution system.

Power semiconductors, (thyristors or SCRs) are used to undertake the switching process. These are many times faster and more rugged and reliable than their electromechanical equivalents.

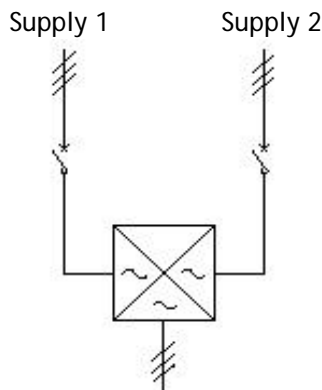

Fig. 1.

Load

The Static Transfer Switch continuously monitors the supply sources and should the supply presently connected to the critical load fail or degenerate to not be useable by the critical load the critical load is automatically and transparently transferred to the alternate source.

This switching process is undertaken as a break-before-make. The break in the supply transition is so short that it is not seen by the critical load. This is preferable to a make-before-break (or overlapping) change-over because when the two supplies are different and connected together large and unpredictable currents would flow between the sources degenerating both supplies and therefore the supply to the critical load.

2. CONTROLS

Front Panel Controls

The front panel as depicted only has one control pushbutton, “TRANSFER”. This toggles between the two supply sources. Throughout this manual they will be referred to as “Supply 1” and “Supply 2” respectively. The output, (LOAD) for the critical load will be referred to as “Supply 3”.

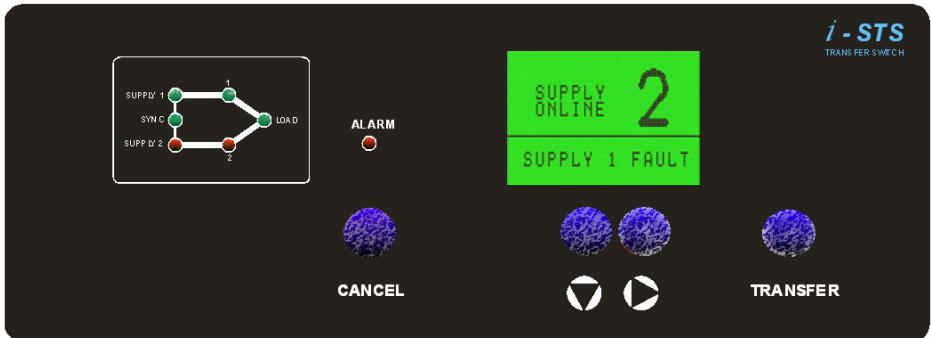

The LCD section of the control panel has two additional screen information selection control pushbuttons; however, these do not perform any operational function.

There are other user controls; however, these reside within the enclosure and / or via the HLI interfaces. These additional controls are not required for normal operation.

Depiction may vary depending on model.

3. LED INTERFACE

LED front panel controls consists of only one manually operated transfer switch pushbutton. The user must press and hold for At least 2 seconds to affect a manual transfer to the alternate supply, (pictured over leaf). Note that manually transferring overrides the preferred source selection at the rear of the unit.

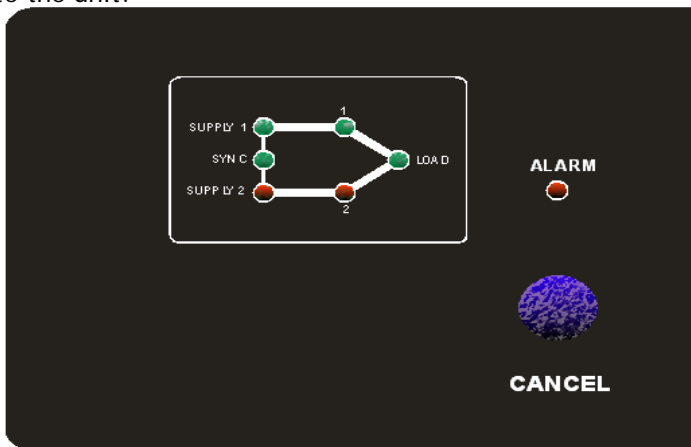

The LED mimic shows a limited number of operational states. These are outlined below. If the Alarm LED is "ON" and the STS condition is not immediately able to be determined from the LED indicators then the user may use the LCD, HLI port or voltage free contact status to further interrogate the unit.





SUPPLY 1	Green -> Available Green Flashing -> Not within Specification Red -> Failed
SUPPLY 2	Green -> Available Green Flashing -> Not within Specification Red -> Failed
1	Green -> On Line (connected to critical load) Red -> Not on (NOT connected to critical load)
2	Green -> On Line (connected to critical load) Red -> Not on (NOT connected to critical load)
SYNC	Green -> In synchronism Green Flashing -> Occasionally in Synchronism Red -> Not in synchronism
LOAD	Green -> Normal Red -> Alarm (flashing) -> Overloaded

4. LCD INTERFACE

A red LED "ALARM" is used to indicate a non normal condition or state. The LCD will indicate the nature of the abnormality.

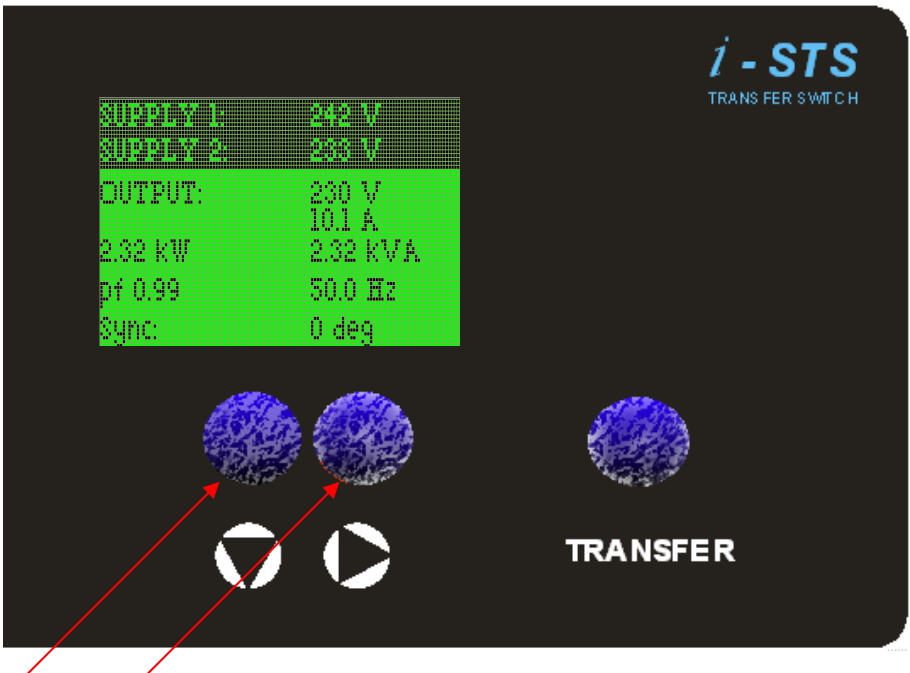
Navigation through the LCD hierarchy allows screen function selection using the  key. Additional information is available on subsequent screens, such as Event History and Set-up. These are accessed using the  key.



When  requested the LCD indicates the supply quantities for the "R" phase. The display automatically toggles through the three phases.

To affect a transfer to the alternative supply manually the user must press and hold the TRANSFER pushbutton for at least 2 seconds.

Load Power Quality Analyser

Current => waveform
Voltage => _____ waveform

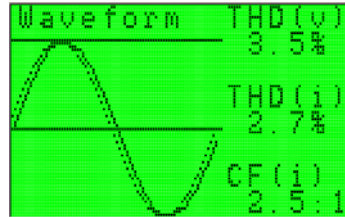

Note that both voltage & current waveforms are normalized and do not represent any magnitude attributes.

The waveform with lesser amplitude is always the current.

The display automatically toggles through the three phases.

Harmonics are analysed to 13th

Event List

Event List (100 events)

Use  to view more

```
10.02.04 01:45:23 SW 1 OK  
10.02.04 01:45:23 PREF 2  
10.02.04 01:45:23 LOAD FLT  
10.02.04 01:45:23 ROM  
10.02.04 01:45:23 EPPM  
10.02.04 01:45:23 O/LD WRN  
10.02.04 01:45:23 SP 1 FLT  
10.02.04 01:45:23 1FLT LOW  
10.02.04 01:45:23 1FLT OK
```

Refer to Section 13 for a description of the event codes.

This diagram shows the available options and how to navigate through them:

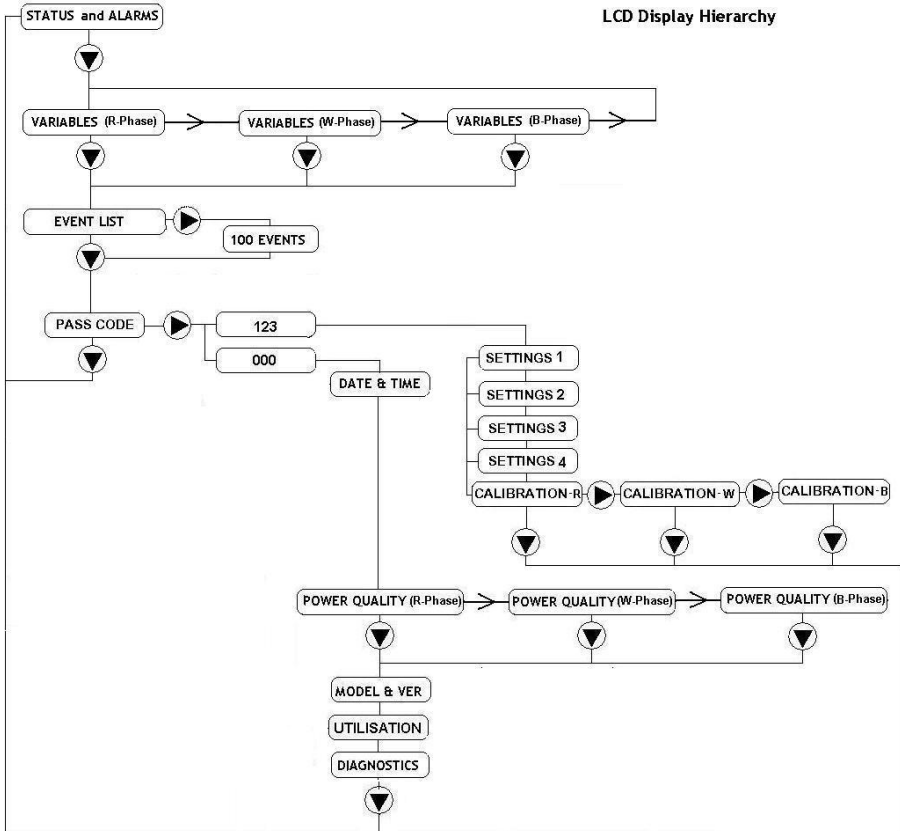

STATUS shows which supply (1 or 2) is connected the critical load.
This supply also indicates any pending alarm condition.

VARIABLES indicates the input and output electrical parameters for each phase.

POWER QUALITY assessment is made by visually showing a snap shot of the voltage and current waveforms. Crest factor and a harmonic analysis of the waveforms provide a power quality estimate for the load. Also available for each phase.

EVENT LIST Any changes of state and or alarms generated are recorded in real time in a circular 100 event buffer.

A **PASS CODE** is required to gain entry to the **SETTINGS**, **DIAGNOSTICS**, **CONFIGURATION** and **CALIBRATION** screens etc. (User access allows changing of values within recommended limits, a second level allows access to other not normally used access points / values).

RESERVED may contain specific options and configurations applicable only to your units.

Additional set-up / configuration and calibration screens are accessible only by entering the correct passcode.

It is important that the user understands the consequences of the changes made within these menus as unpredictable and incorrect operation may result if settings are incorrectly set.

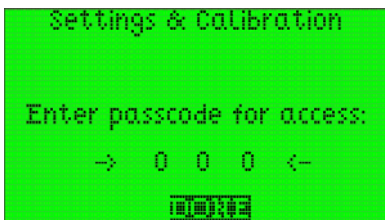

Incorrect setting is not covered by the warranty. Refer to Section 7.

Accessed by entering PCODE "000" access to the Set Date & Time Screen is enabled.



For example to set the time from the Configuration screen press the  key.

A cursor will then highlight the variable field.

Press the  key to vary the field.

Holding the key for more than 2 seconds will allow a fast scroll.

When set to the desired value use the  key to move to the next field and repeat the process.

Accessed by entering PCODE "000" (Version control)

```
Model Number:
i-STS100 f A
Firmware:
if003921-M430c&b
For service call
+613 9431 0494
```

STS Utilisation Screens

```
Utilisation
Hours on Supply 1: 243
Hours on Supply 2: 397
Hours on Preferred: 476
Hours Operating: 640
Hours Inactive: 4
More
```

```
Forced Transfers: 2
Sync Losses: 4
Load Faults: 8
Supply outages: 5
Load Fault: 10:43:35 16.06.04
Outage: 10:41:05 16.06.04
```

Diagnostics Screens (see also Section 14)

```
Diagnostics
Overloaded
Supply 2 Forced
MORE
```

The diagnostics screens show the present state or alarm condition or fault.

By entering the user access Passcode "123" access to setpoints is provided

Where appropriate there are two sets of set-points. One is active for manual activated transfers "MAN" whilst the other "AUTO" is active for all normal operation.

Set	Auto	Man
\$1 fast Hi	125	125
\$1 fast Lo	80	80
\$2 fast Hi	125	125
\$2 fast Lo	80	80
Fast Pause	2	
ReTx Pause	5	
ReTx Tries	3	

Set	Auto	Man
\$1 S/S Hi	110	110
\$1 S/S Lo	90	90
\$2 S/S Hi	110	110
\$2 S/S Lo	90	90
S/S Pause		1.5
Phase Norm	10	10
Phase Fault	30	

Set	Auto	Man
\$3 S/S Hi	110	110
\$3 S/S Lo	90	90
\$3 fast Hi	120	120
\$3 fast Lo	80	80
Current Low	10	
Curr 110/125%	60	20
Curr 150/200%	10	1

Set	Auto	Man
Hz	5	5
Preferred	0	
Mode	\$	\$
Peak I		0
Fan Mode	None	
User PCode	123	
User In		1

Calibration Menu

Calibration	Read	Actual
\$1 Volts	240	240
\$2 Volts	240	240
\$3 Volts	240	240
\$3 Current	50	50
\$3 kW	50	50
\$3 kVA	50	50
\$3 CF	1.3	1.3
Phase	5	5

5. USER IO & CONTROLS

These are located within the STS enclosure, top RHS of the panel as shown.



PREFERRED SOURCE SELECTION (pre-set)

0	No preferred source
1	Supply 1 is the preferred source. If STS is forced to automatically transfer the critical load to the alternate (Supply 2) source the STS will automatically transfer back to Supply 1 when again within tolerance and a pre-set settling delay.
2	Supply 2 is the preferred source. If STS is forced to automatically transfer the critical load to the alternate (Supply 1) source the STS will automatically transfer back to Supply 2 when again within tolerance and pre-set settling delay.

CONTROL OVERRIDE (CAUTION for Maintenance ONLY)

0	Normal - Automatic
1	Control Override -> Supply 1 is forced to supply the critical load directly overriding any internal control logic.
2	Control Override -> Supply 2 is forced to supply the critical load directly overriding any internal control logic.

RS232 PORT (The RS232 port has not been enabled on this model)

All settings and calibrations can be performed through the front LCD control panel.

6. USER ACCESS

CAUTION

The power cabling should not be run adjacent to user controls. Separate these control cables from power circuits by at least 300 mm. The control signals are distance limited to 30 metres.

All output relays contacts are rated for 50 V DC 1 Ampere (Not 240 V AC rated)

User Remote Inputs (Voltage free contact closure controllers only)

COMM -> Common return

a -> Transfer to Supply 1

b -> Transfer to Supply 2

c -> Fire Stop (Causes both Switches to go off - loss of output)

User Relay Outputs

Relays are normally closed and held open in OK state (closed contact represents the alarm state).

A -> General Alarm

B -> Not in Synchronism

C -> Supply 1 OK

D -> Supply 2 OK

E -> ON Supply 1

F -> On Supply 2

G -> Overloaded

7. SETTINGS AND CALIBRATION

- Screen 1



Pass code “000” when entered provides access to hardware & software version numbers, Preferred Source selection and pending diagnostic messages. Pressing the  key provides access to the Date & Time Setting function

Password 123 provides access for that allows adjustment of the screen parameters as shown and calibration.

- Screen 2

Set	Auto	Man
S1 S/S Hi	110	110
S1 S/S Lo	90	90
S2 S/S Hi	110	110
S2 S/S Lo	90	90
S/S Pause		1.5
Phase Norm	10	10
Phase Fault	30	

Comment

Steady State High % from nom 105 - 120 % (110%)
 Steady State Low % from nom 0 - 95 % (90 %)
 Steady State High % from nom 105- 120% (110 %)
 Steady State Low % from nom 0 - 95% (90 %)
 Averaging time constant 1 - 3 sec (1.5 sec)
 Allowable window for manTX 1 - 180 deg(10deg)
 Allowable TX fault conditions 1 -180 deg 30deg)

- Screen 3

Set	Auto	Man
S1 fast Hi	125	125
S1 fast Lo	80	80
S2 fast Hi	125	125
S2 fast Lo	80	80
Fast Pause	2	
ReTx Pause	5	
ReTx Tries	3	

Transient High limit % from nom 108-135% (125%)
 Transient Low limit % from nom 92 - 0 % (80%)
 Transient High limit % from nom 108-135% (125%)
 Transient Low limit % from nom 92 - 135% (80 %)
 1 - 100 msec (2 msec)
 Auto re-transfer delay 0 - 300 sec (5 sec)
 No. of Auto-re-transfers 0 - 5 (0 inhibits), (3)
 (Allowable before lock out, locked out until manually re-transferred)

- Screen 4

Set	Auto	Man
SS s/s Hi	110	110
SS s/s Lo	90	90
SS fast Hi	120	120
SS fast Lo	80	80
Current Low	10	
Curr 110/125%	60	20
Curr 150/200%	10	1

Output Steady State High % from nom 108-135%(110%)
 Output Steady Low % from nom 80-95%(90%)
 Output transient High % from nom 108-135%(120%)
 Output transient Low % from nom 80-95% (80%)
 Low current threshold (10%)
Overload time (min) @ 110 & 125 % Overload
Overload time (min) @ 150 & 200 % Overload

- Screen 5

Set	Auto	Man
Hz	5	5
Preferred	0	
Mode	S	S
Peak I		0
Fan Mode	None	
User PCode	123	
User In		1

Deg from 50Hz +/- 9Hz (5Hz)
1 or 2 or 0 (none) - (0), only if switch at rear in centre.
S, F or B (S), only settable for Mode type sf
150 - 600 % (500 %)
0 None, 1 Current, 2 Temp(0)
 123
 1 toggle, 2 1&2, 3 no STOP (2)
 (refers to operation of user inputs a, b & c)

For a description of the calibration process see section 15.

8. INSTALLATION

i-STS C comes already assembled ready to install.

The most crucial aspects of the install are:

- Safety:
- Damaged to Goods
- Electrical Connectivity
- Mechanical integrity.
- Cooling

Safety is by far the most important aspect.

Signage... This equipment is powered from two separate sources. It is important that you install correct signage and procedures within the enclosure and it's immediate vicinity to warn personnel of this aspect and what isolation, checking and precautionary processes and procedures need to be adopted to make the STS and equipment connected to the STS safe to work on.

CAUTION

THIS EQUIPMENT RECEIVES POWER FROM MORE THAN ONE SOURCE. DISCONNECT OUTPUT AND ALL INPUT SOURCES OF POWER FROM THIS EQUIPMENT BEFORE SERVICING.

CAUTION

REMOVAL OF THIS PANEL EXPOSES DANGEROUS VOLTAGES

ACCESS RESTRICTED TO QUALIFIED PERSONNEL ONLY

Do not proceed with the installation or operation of the STS if it has been damaged. Carefully inspect the STS for any damage that may have occurred during shipping, unpacking or during and after any installation process.

Take care when handling the items and ensure that it is physically supported during the installation process. At the end of the installation process the STS should be firmly and securely bolted within the enclosure.

Make sure that you employ a licensed electrical contractor to install the STS. Check that the enclosure and the STS are correctly Earthed. Ensure also that all of the cables are securely connected and supported and that all safety covers are installed. There should be NO live exposed or accessible contacts that would / could cause electrical shock if contact is able to be made.

WARNING

HIGH LEAKAGE CURRENTS ON ISOLATED INCOMING
AND OUTGOING CIRCUITS

EARTH CONNECTION IS ESSENTIAL BEFORE
WORKING ON CIRCUITS OR CONNECTING /
DISCONNECTING SUPPLIES.

SEE INSTALLATION INSTRUCTIONS BEFORE CONNECTING /
DISCONNECTING INPUT SUPPLIES.

Ancillary controls connections are as described in Section 6 of this manual. It is prudent to provide physical separation between control circuits and power circuits. This avoids confusion, reduces interference and increases the reliability of your installation. Again make sure that all control wiring is protected and securely supported so that it is not inadvertently unplugged or removed whilst other equipment is being installed or removed within the enclosure.

The equipment dissipates heat (see specifications for exact heat dissipation). Even when the load is small. Do not stop fans whilst there is incoming supply power to the equipment. Do not block air entry or exit.

Provided these precautionary aspects are headed the STS will provide you with a reliable back-up supply capability.

Before powering the STS up ensure that the load side is safe and any equipment or cabling connected is ready to be safely powered up.

To power up operate the external isolators to the on position. The LCD should illuminate the instant power is applied, and after a few seconds of diagnostics initialization a message should appear and some 10 seconds later the STS should activate and switch the output to the preferred source.

9. SET-UP AND COMMISSIONING

Read this whole document thoroughly. Understand every aspect before proceeding. Request further assistance if you do not understand any aspect of the operation of the STS. Support and contact numbers are at the rear of the manual.

Consider electrical distribution discrimination carefully. The STS has no internal thermal protection. Protection against overload and fault for the STS is provided by upstream circuit breakers. These should discriminate with down stream protective devices so that other items connected to the STS are not powered off by the tripping of a circuit breaker / protective device upstream due to a down stream fault condition. The fault setting should ensure that the prospective fault current is limited to below the destruction level of the thyristors which is 15 kA peak.

In case of down stream fault the STS will not transfer the fault to the alternate supply even if the voltage is adversely affected. Once the fault current has cleared and the voltage is again within operating limits the STS will resume normal operation protecting the critical loads from voltage disturbances, (10 second settling time).

After following all of the considerations and precautionary processes in the last section and been successful and understanding, then no further special set-up is necessary.

The fans should be operating. The fans speed varies according to the following:

- At low loads (< 125 amperes) both fans operate at low speed
- At higher loads both fans operate at medium speed
- If one fan has stopped then the other fan operates at full speed
- If there is a fan failure or overtemperature both fans operate at maximum speed

DO NOT STOP THE FANS FROM OPERATING WHEN POWER IS APPLIED

The red LED ALARM should not be on.

If it is check the following states.

- ON Supply 1 when priority is Supply 2
- On Supply 2 when priority is Supply 1
- Supply 1 or Supply2 are not in spec.
- Override Switch is in position 1 or 2
- Supply 1 & 2 are not in synchronism
- The unit is too hot (thermal bi-metal switch on H.S. activated)
- There is / was an overcurrent/ overload / load fault condition

Ensure from the supply that you are connected to on the STS and the supply selected by the Maintenance Bypass Switch supply are the same (e.g. supply 1 on both). Open the remote maintenance. The critical load should be being supplied by the STS.

Use the TRANSFER push button to transfer to the alternate supply. To affect a transfer you need to push and hold the transfer pushbutton for at least 2 seconds. The LCD should show that it is now powering the load from the other supply, (non preferred & LED should come on to indicate this).

If the unit does not transfer check that the two supplies are available and in synchronism, (use variables display page).

Check that the rear control OVERRIDE switch within the STS enclosure (RHS) is in the centre "O" position for normal operation.

If the a load item circuit breaker trips at turn-on it is probably due to it's equipment internal inrush current, not the STS.

If a circuit breaker upstream of the STS trips there is probably a discrimination error in the protection aspects of the electrical distribution or there is a major fault within the STS.

The RED ALARM Led should be off.

10. MAINTENANCE & BYPASS OPERATION

The Static Transfer Switch (STS) provides power to items requiring a single AC supply. The STS selects this supply from one of two input AC supplies. If one of the supply sources becomes unavailable the STS will automatically transfer the critical load to the alternative AC supply source.

Manual selection of supply is also possible. This is accomplished using a procedural sequence and mechanical interlocking. The STS is not electrically or mechanically interlocked with the external switches and isolators so extra care should be taken following these procedures to ensure that the supplies are not inadvertently paralleled or that the critical load power is lost.

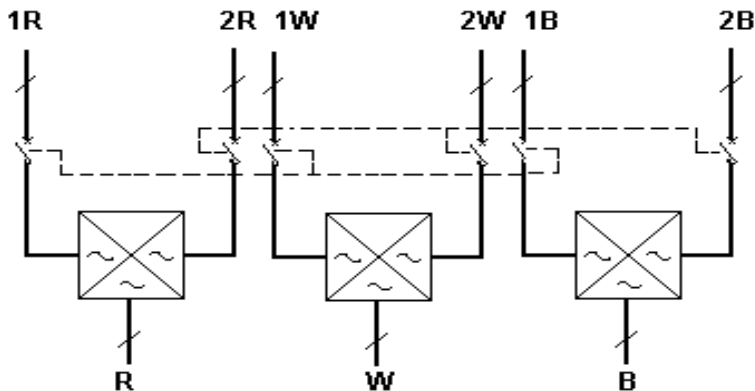

In the case of a control failure the STS internal control logic can be overridden and the output can be forced to the correct state using the OVERRIDE switch to position 1 or 2 as appropriate. Remember that the switch needs to be in the centre “O” position for normal operation.

The override provides control logic bypass only' it does not provide an alternative path for the load power.

NEVER attempt to operate the OVERRIDE switch if the supplies are not in synchronism. There is no interlock to prevent the switch from being operated when the supplies are not available or not in synchronism. Refer to the LCD variables display and mimic diagram for the not in synchronism state, (SYNC LED will be RED, variables display will show degrees out of synchronism. Only operate when less than 10 degrees). If the control is not operating you may need to use other means to determine that the supplies are in synchronism. Do not operate the OVERRIDE switch onto an absent supply.

Do not defeat the mechanical and or electrical interlock scheme.

Always CHECK and ensure that the STS is in the correct state (on supply 1 or 2) equivalent to the Supply that you want to transfer to.

11. CABLING

Do not Megger. Do not undertake insulation Resistance Tests when STS is connected.

This unit has leads for power connection. As:

Supply 1	3 active conductors, R, W and B (120mm ²)
Supply 2	3 active conductors, R, W and B (120mm ²)
Supply 3	3 active conductors, R, W and B (120mm ²)
Neutral	1 conductor to terminal (1.5mm ²)
Earth	On cubicle @ (16mm ²)

Always have the Output Cables terminated when power is connected to the STS.

The neutrals are bonded externally, however the STS does require a low current control neutral connected to the neutral terminals inside the enclosure.

CAUTION

THIS EQUIPMENT RECEIVES POWER FROM MORE THAN ONE SOURCE. DISCONNECT OUTPUT AND ALL INPUT SOURCES OF POWER FROM THIS EQUIPMENT BEFORE SERVICING.

WARNING

HIGH LEAKAGE CURRENTS ON ISOLATED INCOMING AND OUTGOING CIRCUITS

EARTH CONNECTION IS ESSENTIAL BEFORE WORKING ON CIRCUITS OR CONNECTING / DISCONNECTING SUPPLIES.

SEE INSTALLATION INSTRUCTIONS BEFORE CONNECTING / DISCONNECTING INPUT SUPPLIES.

This page intentionally left blank.

12. INTERPRETATION OF EVENT LIST

The explanatory text on the LCD screen has intentionally been abbreviated.

INIT RAM		CHKsum failed — Cold Start (RAM Corrupt)	Alarm Notify for Service
BOOT		Warm Start, re-initialize all but RAM	Event - No action
WDOG		Signals software / hardware problems	Alarm Notify for Service
STAC	FLT	Stack or Heap has overflowed	Alarm Notify for Service
EEPM	FLT	EEPROM Checksum error — cal may be damaged	Alarm Notify for Service
ROM	FLT	ROM has been corrupted	Alarm Notify for Service
BATT	LOW	Battery has low power (needs replacing)	Alarm Notify for Service
COMS	1/2/3/4/5/6	Communications has failed to MSP1,2,3,4, 5, 6	Alarm Notify for Service
CAL	1/2/3	Calibration of MSP 1,2,3 required	Alarm Notify for Service
SP1T	FLT / OK	Supply 1 has failed (no supply)	Transfers to supply 2 if on 1
SP 1	LOW /OK	Supply 1 Steady State Low (1 sec)	Transfers to supply 2 if on 1
SP 1	HI / OK	Supply 1 Steady State High (1 sec)	Transfers to supply 2 if on 1
HZ 1	LOW / HI / OK	Frequency of supply 1 is high or low	Alarm No action
SYNC	LOS / OK	Output is not in synchronism with alt. supply	Alarm No action
SP2T	FLT / OK	Transient Event that Incoming Supply too high	Transfers to supply 1 if on 2
SP 2	LOW /OK	Transient Event that Incoming Supply too Low	Transfers to supply 1 if on 2
SP 2	HI / OK	Supply 2 has failed (no supply)	Transfers to supply 1 if on 2
HZ 2	LOW / HI /OK	Frequency of supply 2 is high or low	Alarm No action
SP 3T	FLT / OK	Output Supply 3 has failed (no supply)	Transfers to alternate supply
SP 3	LOW OK	Output Supply 3 Steady State Low (1 sec)	Transfers to alternate supply
SP 3	HI / OK	Output Supply 3 Steady State High (1 sec)	Transfers to alternate supply
O/LD	WAR / OK	Output is overloaded	Alarm reduce loading
LOAD	FLT / OK	Output has experienced a load fault	Inhibits transfer to alt. supply
CURR	HI/ OK	Output is overloaded	Reduce load on STS
FAIL	S1 / S2 / S3	Supply source has failed	Reinstate Source S1/S2

OVRD	1 / 2 / 0	Manual override switch set to 1 or 2 or none	Locks to selected supply
PREF	1 / 2 / 0	Preferred Source SW 1 or 2 or None selected	Status - No action
THDI	HI / OK	Total harmonic Distortion of current is very high	User Alarm / Status- Check Load
THDV	HI / OK	Total harmonic Distortion of Voltage is too high	User Alarm / Status- Check Load
HSOT	HI/LO	Heat Sink is Over temperature Calls	Fault — Inhibits Output
FAN	FLT / OK	Fan Failure (if applicable)	Alarm Notify for Service
LPM	1 / 2 / 3 /OFF	Indicates that data preserved by battery	Status / debug indication only
RMTX	1 / 2	Remote Transfer Request	Status indication only
LOTX	1 / 2	Local Transfer Request	Status indication only
XFER	1 / 2	Transfer to 1 OR 2 occurred	Status Transfers to Supply #
VARF	FLT /OK	Varistors failed	Alarm Notify for Service
PWRS	1/2/3	Power supply monitoring	Restore S1,S2, S3 or PRS failed
SCRS	S1 / S2	Detected open circuit thyristor	Inhibits transfers
SCRO	S1 / S2	Detected short circuit thyristor	Inhibits transfers
ALMC		Front panel pushbutton has been pressed	Status indication only
BKFD S	1 / S2	>40 V Pk on incoming S1 or S2 when S1 or 2 failed	CAUTION Shock Hazard on S1&S2

13. Fault Diagnosis & Maintenance

The STS s has been manufactured to provide a long, reliable and useful life. However, all equipment needs some maintenance.

Recommended Schedule

Once per month record the operating variables and compare with the units specifications to ensure that you are within its operating capability. Inspect the unit and note down any variations from last observation. Action may need to be taken and or reporting may need to be taken on these variances.

It would be prudent to attempt a Transfer periodically to ensure correct operation.

Once every 6 months, (sooner if the environment is bad), vacuum dust from grills (top / bottom) or (front / rear) of unit.

Inspect cable / plug connections for overheating.

Units with fans need their fans changed every 7 - 8 years, (70,000 Hrs life). Check that the fans are operating and at the correct speed.

Should you need to reset the unit because the LCD screen has become corrupt or you have lost control then this can usually be recovered by pressing the three buttons on the front panel simultaneously for 2 seconds.

NOTE

Please note that the user should not undertake repair procedures or gain access to the internals of the equipment. If the unit is faulty then it should be removed from service as per the accompanying procedure and returned for repair.



The diagnostics screen provides information in respect to the present condition or status of the STS. As many items will be indicated as necessary to describe any abnormal condition.

By selecting  (More) hardware diagnostics determine the deviation of the normalized incoming voltages with the activation levels. If an error of greater than 3% exists it may be prudent to adjust the steady state and /or transient levels in the "Settings Menu"

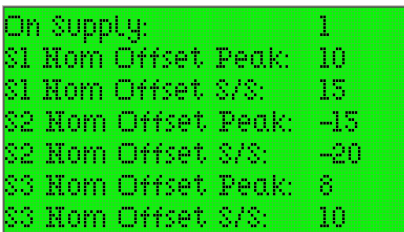

e.g.

To compensate for other than nominal input voltage (say S1) adjust the High and Low parameters for S1 transient high (fast) values Hi & Lo up by 10% to compensate for the larger than anticipated incoming voltage.

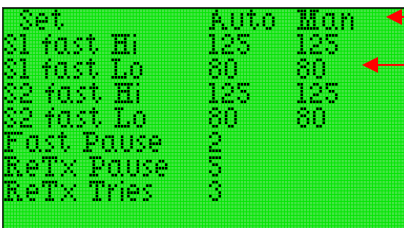

Adjust these to 135% and 90 %
Similarly for S2 to 110% and 65%

Repeat process for steady state (S/S) values and S3 supply

14. CALIBRATION

After entering the correct password access to the following adjustment screens is available.

The user should use caution in adjusting any of the operational variables as incorrect setting may cause incorrect operation and or loss of the critical load.

The following screens indicate the contents and functionality.



Access is provided by entering the passcode "123" and using the  key until this screen is shown.

- Screen 5

Calibration	Read	Actual	
01 Volts	240	240	240 Volts RMS
02 Volts	240	240	240 Volts RMS
03 Volts	240	240	240 Volts RMS
04 Current	5	5	100 % RMS
05 kW	5	5	Calculated kW
06 KVA	5	5	Calculated V *A
07 CF	1.3	1.3	1.4 or peak / RMS calculated
Phase	5	5	in degrees supply1 to supply2

User measures Actual using a reference meter and types in the value under the column 'Actual'.

'Read' is the present value as indicated on the variables page.

If using the LCD then use the  key to move to the correct field and then the  key to scroll to the correct value.

Once completed an exit is affected by  key through the selection list past the last calibration option.

15. DRAWINGS & SCHEMATICS

16. PARTS LIST

Part	Description	Manufacturer	Part Number	Rating
THYM1-6	THYRISTORS	SEMIKRON/IR/EUPEC	TT500-18	500 Amps RMS , 17KA
SNB1,	DV/DT LIMITER	SP	SKC1033C	100 v/usec
CT1	CURRENT TRANSFORMER	WF ENERGY CONTROLS	AS400:1	100 Amps
FANS	TANGENTIAL BLOWER	ZIEHL / EBM	D2E133-AMB3-88	5 SPEED / 240 V AC
PLC1	LHS FAN CONTROLLER EASY	MOELLER	412 DA-RC	12 V DC
PLC2	RHS FAN CONTROLLER EASY	MOELLER	412 AC-RC	240 V AC
CR1	FAN CHANGEOVER CONTACTOR	MOELLER	DIL22 ER	240 V AC
RI1-4	DIN SLIMLINE RELAYS	OMRON	DTN-2-SN	240 V AC
F1-F7	DIN FUSE HOLDER	PHEONIX	UK5-NESI	240 v AC
F1-F7	CONTROL FUSES	PHEONIX	CERAMIC SLOW BLOW	10 Amp 20-25MM
SENSOR	FAN PROXIMITY SWITCH - IND	BELL ELECTRIC	TS18-08P-1	12 V DC 18MM PNP NO
PRS1-3	REGULATED POWER SUPPLY	MEANWELL	RD-65A	240/12/5 65 VA
SP001a	POWER CONTROL BOARD	STATIC POWER	SP001-02	n/a
SP001b	POWER CONTROL BOARD	STATIC POWER	SP001-02	n/a
SP002	STS CONTROL BOARD	STATIC POWER	SP002-01	n/a
SP003	DISPLAY BOARD	STATIC POWER	SP003-00	n/a
SP004	USER I/O BOARD	STATIC POWER	SP004-01	n/a
SP005	PARALLEL CONTROL BOARD	STATIC POWER	SP005-02	n/a
SP011	FIRING BOARD	STATIC POWER	SP01101	n/a

17. WARRANTY - CONTACT & SERVICE INFORMATION

The unit is warranted for 12 months from date of manufacture.

Static power will repair or replace faulty items should the unit become defective as necessary.

In the event that you wish Static Power Pty. Ltd. to come to site service charges and travelling expenses will result.

i - STS Manufacturing is a subsidiary of **STATIC POWER PTY. LTD.**
ABN 42 101 765 913

Factory @ 5/39-45 Susan Street Eltham, Victoria Australia, 3095
Mail to: , BOX 2003 Research Delivery Centre, Research 3095

for Service: Phone 03 9431 0494 (BH)

 Mob 0414323 890 or 0410 445 362

 Email support@i-sts.com.au

 or visit www.i-sts.com.au

Warranty is void if not installed as per the instructions and cautions as outlined in this manual or if operated outside of its specification.

