

# Static Bus Tie MODEL SBT

When implemented in dual cord UPS distribution systems, Static Bus Ties (SBTs) significantly increase UPS power availability. Normally, both loads are supplied independently by their respective UPS - the SBT provides a secondary UPS supply in case of UPS failure. SBTs also make full UPS maintenance possible without any loss of critical power.

### What does an SBT do?

The SBT generally operates in 'stand-by' mode, where each critical load bus is supplied by its own UPS source. During UPS fault conditions, the SBT will initiate a transition by closing its static switch. The faulty UPS is isolated and supply is maintained to both loads via the Bus Tie by the remaining UPS. A manual closure can also be initiated by the operator via the front panel controls. All transitions are safe and automatic.

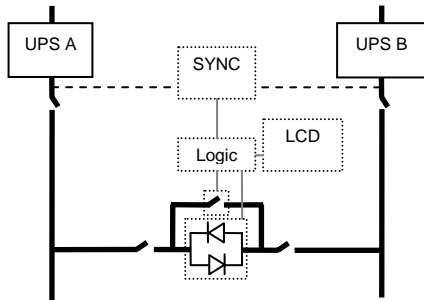

Each transition switching function incorporates static and electromechanical connection and isolation of the UPSs to increase the availability of conditioned power to the loads. The Static Switch is bypassed by closing the electromechanical bridge (larger SBTs only).

The SBT also simplifies the power cabling infrastructure than what is able to be achieved using a dual static transfer switch solution, only needing a single 4 core cable between each critical bus and the Static Bus Tie.

### Monitoring

User LCD controls allow visual confirmation of operating state, manual operation and mode setting. A touch screen graphic LCD display provides a mimic diagram, status indication, mode selection, diagnostics and settings access. The display functions incorporate a real time event buffer (last 64 events) and historical utilization information for system wide collaboration of events.

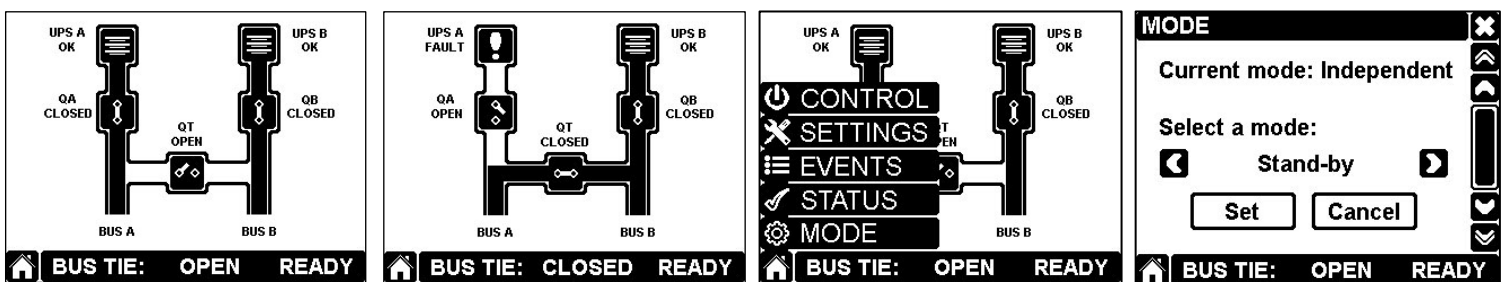

### Modes of operation.

In addition to the conventional operating mode, (stand-by), the SBT enables the supplies to operate in two continuous parallel modes. These modes are described as 'redundant mode' and 'parallel mode'. Both of these modes are designed to increase your overall system availability, offering true redundancy with the security of fault isolation. These modes are especially helpful in an environment with short term increasing load demands.

#### Independent

In this mode the SBT is **always open** and the critical load is supplied by each UPS independently. The automatic function of the SBT is disabled, but still available for the operator to engage when UPS maintenance is being performed. The user may also consider this mode when the load on the sum of the UPSs exceeds the rating of a single unit.

#### Stand-by

Stand-by mode ensures redundant UPS supply is made available to the critical load. The SBT is **normally open**, with both units operating independently. If the event of a UPS failure the **tie is automatically closed** and isolating the failed UPS. The remaining UPS continues to supply both loads through the SBT.

#### Redundant

This mode provides full parallel redundant UPS operation where the SBT is **normally closed**. If one UPS was to go off line then the faulty UPS would be isolated, leaving the remaining unit to supply both critical loads via the SBT.

#### Parallel

Used where the load capacity is greater than one UPS, parallel mode enables the two UPSs to operate as one. In this mode the SBT is **always closed**. Should a UPS fail then the UPSs would transfer to their respective internal bypass.

#### Maintenance mode

This mode provides a logic controller override function. The Bus tie can be operated **manually to the open or closed position** and is locked in this position until manually reset. There is no automatic functionality and no control functions.

i - STS Features	Benefits
Not a Series element	Increased reliability
Break Before Make Transfers	Prevent paralleling of input sources
Large Overload and Fault Capacity (No fuses)	Suitable for installations with fault capacity up to 35 & 50kA
Guaranteed Load Fault Transfer Lock-out	Will not transfer faults to alternative source
Synchronous and Non-Synchronous Transfers Allowed	Transfer at safely even if sources are asynchronous
SCR Open and Short Circuit Protection	No overlapping or loss of supply due to SCR or control failures
LAN Web Server Option Built Into Hardware	Monitor and control STS through Web Browser software
Redundant Controls and Triple Redundant Power Supply	More secure higher MTBF for your equipment/Redundant power monitoring

# Specifications

These specifications refer to a typical three phase Model SBT Static Bus Tie

Rating	100 - 1250 Amperes RMS
Voltage Rating	415/240 V $\pm$ 20% (other voltages available on request)
Permissible Voltage Distortion	20% THDV
Frequency	50 or 60 Hz $\pm$ 10%
Type	3 + N (3-phase, 4-pole, or 3 phase, 3-pole)
Efficiency	99 % (3P)
Transfer Type	Thyristor
Detection Digital	< 2 msec
dV/dt	>1000 V/ $\mu$ sec
MTBF	> 800,000 Hrs
Device Ratings	3500 Amperes RMS, 1600 Volts, 35 kA 10msec, > 5,000,000 A2Sec
Fault rating	35 kA (or 50kA optional)
Fault Current Setting	300% peak (transfer lock-out)
Protection	Load fault inhibit, voltage failure detectors, synch inhibit
Overload Capacity	Up to 120% for 30 seconds 500% for 0.5 second 1000% Amperes for 100 msec 35,000 Amperes for 10 msec
Remote I/O	4 User Voltage free contacts (50 V DC, 1 Ampere, N/C) + Remote Inhibit
LAN Browser	Optional
Modbus TCP	Optional
Modbus RTU (RS232)	Optional
SNMP	Optional
Operating Temperature	0 - 45°C
Cooling Fan	forced, redundant (Natural < 250 Amperes)
Noise	< 60 dB(A) typically
Physical Size	1900 h x 800 w x 500 d
Cable Entry	Top or Bottom
Maintenance Access	Front only (via double, lockable doors), fully shrouded and compartmented.
Colour	RAL7035 (Riverstone, off white)
Compliance	AS3100 & AS/NZ/IEC 62310-1 (for STSs) AS/NZ(IEC) 62310-1 & 2
Warranty	24 months

Subject to change without notice.

## Static Transfer Switches

*i* - STS Manufacturing is a subsidiary of  
**STATIC POWER PTY. LTD.**  
ABN 42 101 765 913

### Post to:

Box 2003  
Research Delivery Centre  
Research VIC 3095  
Australia

### Manufactured at:

5/39-45 Susan Street  
Eltham VIC 3095  
Australia

Phone: +613 9431 0494  
Fax : +613 9431 0939  
Email : [sales@i-sts.com.au](mailto:sales@i-sts.com.au)  
Web : [www.i-sts.com.au](http://www.i-sts.com.au)